

INSIGNIA™

# 52" Black Metal and Glass Open Frame TV Stand

NS-C1205C



SAFETY INFORMATION AND SPECIFICATIONS....	2
PACKAGE CONTENTS: PARTS.....	3
PACKAGE CONTENTS: HARDWARE.....	4
ASSEMBLY INSTRUCTIONS.....	5
CARE AND MAINTENANCE.....	11

Before using your new product, please read these instructions to prevent any damage.

## SAFETY INFORMATION AND SPECIFICATIONS



**CAUTION:** The top surface of this stand is designed for use with a product weighing no more than 100 lbs. (45.4 kg) and having a width that permits it to sit evenly on the stand with no more than a one-inch overhang on each side of the shelf. Use with products that weigh more than the maximum weight allowed, or with dimensions that extend beyond the maximum width may result in instability, which may result in injury.



**CAUTION:** This product contains small items that could be a choking hazard if swallowed.

Keep these items away from young children!

Model #: NS-C1205C

**Maximum weight:**

**Top shelf:** 100 lbs. (45.5 kg)

**Middle shelf:** 100 lbs. (45.4 kg)

**Bottom shelf:** 100 lbs. (45.4 kg)

**Maximum width:** 1-inch overhang on each side of the top shelf

**Overall dimensions:** (W × H × D):

52 × 20.31 × 19.75" (132 × 51.58 × 50.16 cm)

**Top shelf (W × D):**

52 × 19.75" (132 × 50.16 cm)

**Middle shelf (W × H × D):**

36.25 × 5.75 × 17" (92 × 14.6 × 43.18 cm)

**Bottom shelf (W × H × D):**

44 × 8.25 × 18.75" (111.76 × 24.1 × 47.62 cm)

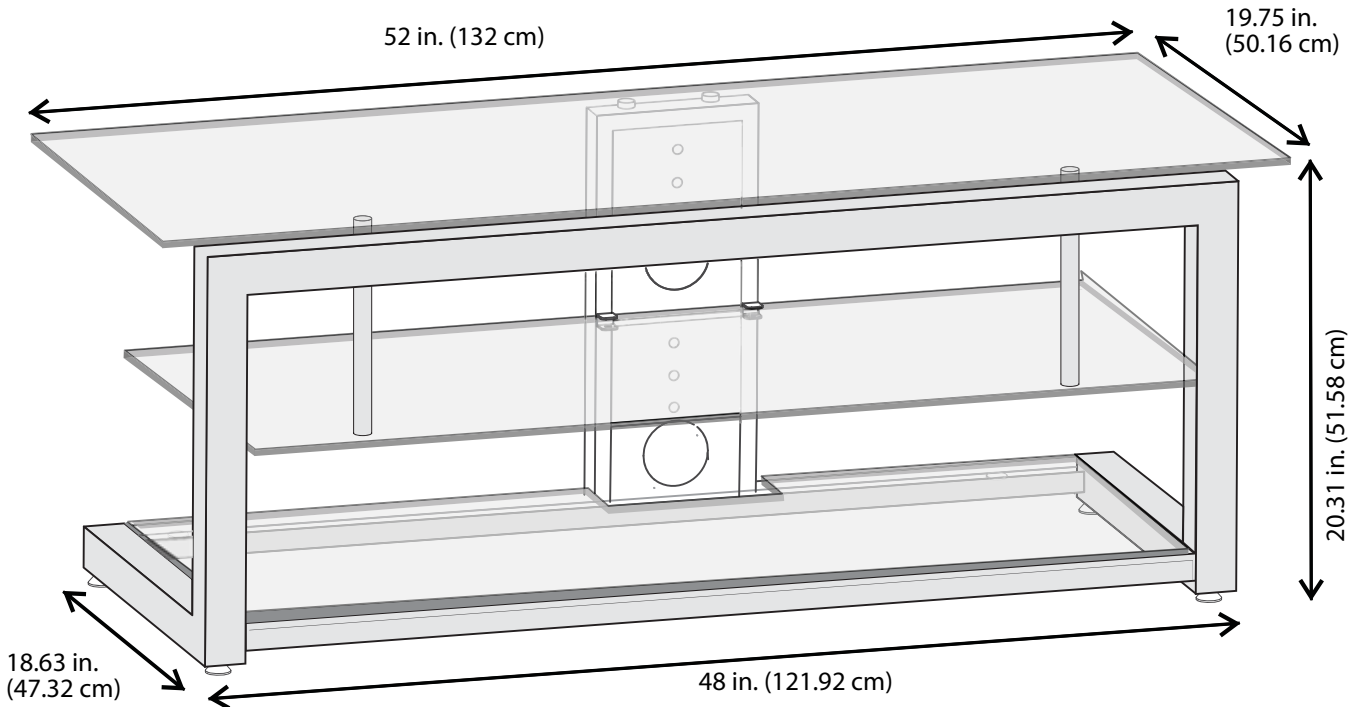

**Tools needed:**



Phillips screwdriver

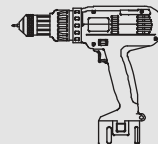

Drill

# PACKAGE CONTENTS: PARTS

**A** Front support (1)

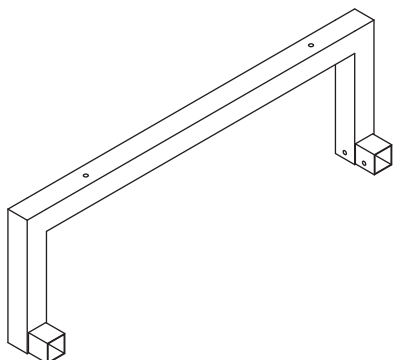

**B** Front base (1)

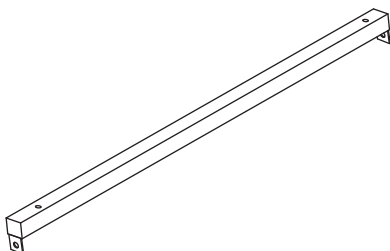

**C** Back base (1)

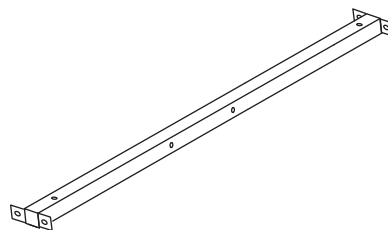

**D** Left base (1)

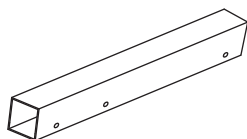

**E** Right base (1)

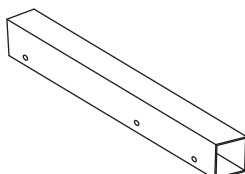

**F** Rear support panel (1)

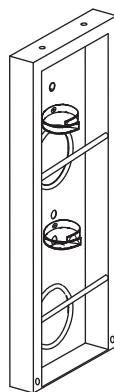

**G** Top shelf (1)

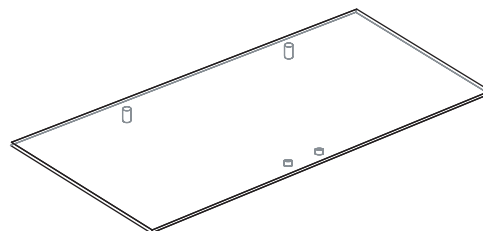

**H** Pillar supports (2)

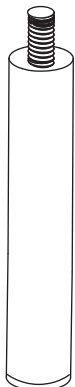

**I** Center shelf (1)

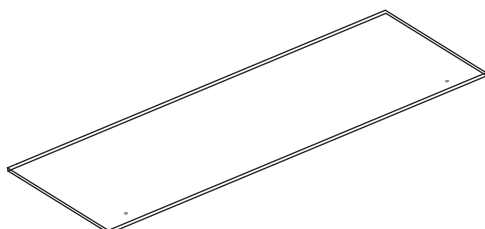

**J** Bottom shelf (1)

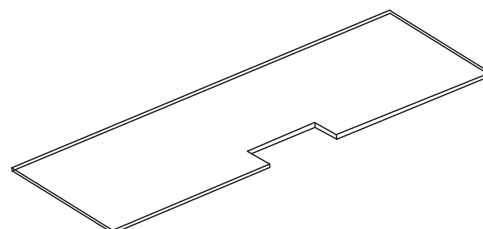



## PACKAGE CONTENTS: HARDWARE

**Note:** You may receive extra hardware.

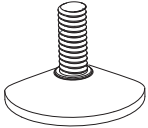
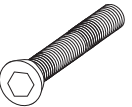
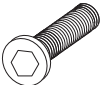
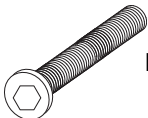
Make sure you have all the hardware necessary to assemble your new TV stand:

Label	Hardware	Qty.
K	 Foot	6
L	 Medium screw	4
M	 Short screw	12
N	 Long screw	2

Label	Hardware	Qty.
O	 Suction cup	4
P	 Clamp screw	2
Q	 Allen wrench	1

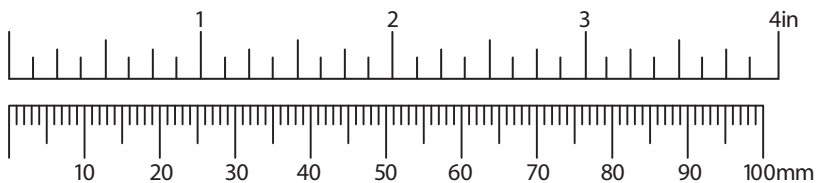

## ASSEMBLY INSTRUCTIONS

### Step 1: Assemble the frame

- 1 Slide the bottom edges of the front support (**A**) into the openings on the left and right bases (**D** and **E**), then secure the bases (**D** and **E**) to the front support (**A**) using three short screws (**M**) on each base (one screw on the inside edge of each base and two short screws on the bottom of each base).
- 2 Align the screw holes on the front base (**B**) with the screw holes on the front support (**A**), then secure the front base (**B**) to the front support (**A**) using two short screws (**M**).
- 3 Align the screw holes on the back base (**C**) with the screw holes in the left and right bases (**D** and **E**), then secure the back base (**C**) to the left and right bases (**D** and **E**) using two short screws (**M**) on each end of the back base (**C**).

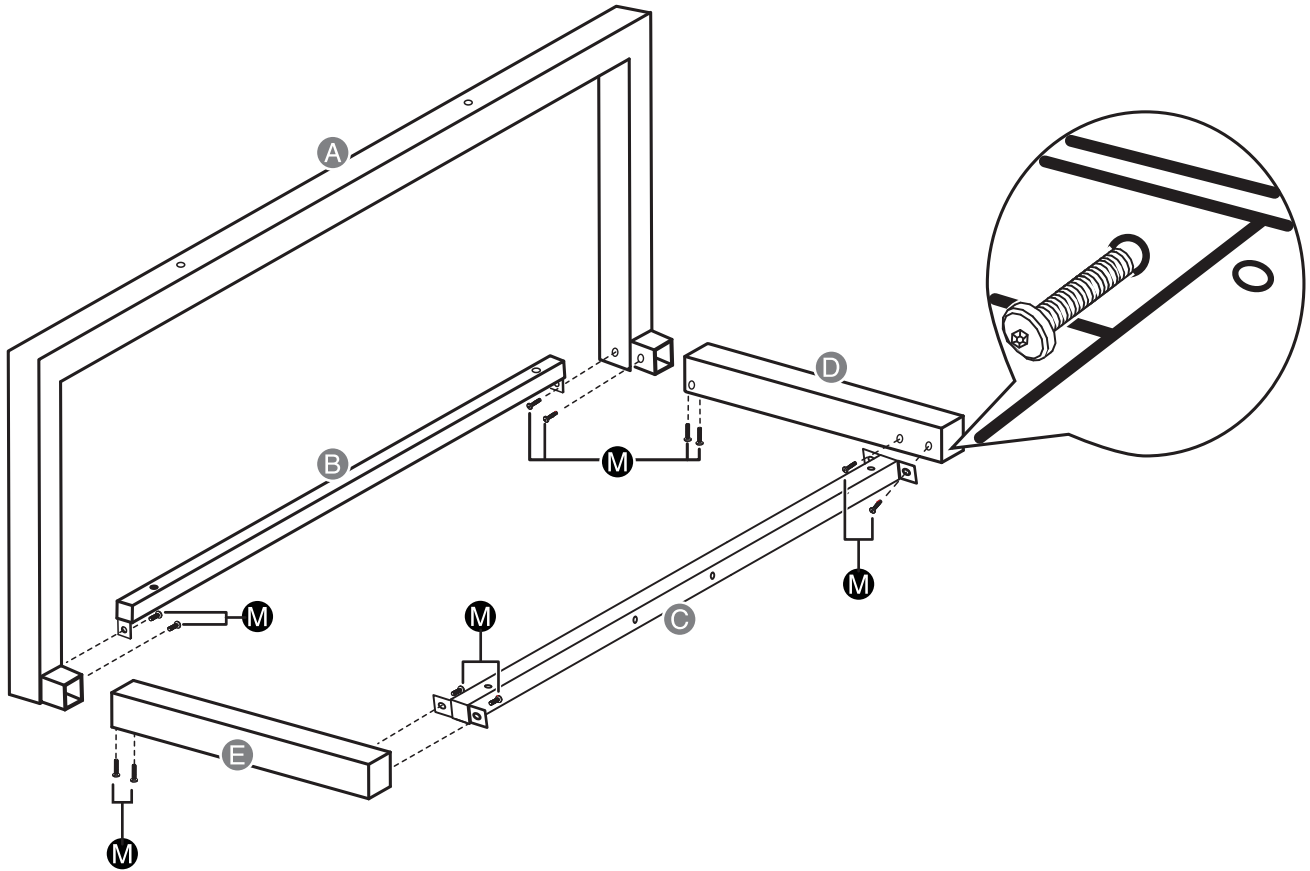

#### You'll need:

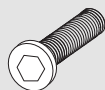

**M** (12)



**Q** (1)

**Step 2: Attach the rear support**

- Attach the rear support panel (F) to the center of the back base using two long screws (N).

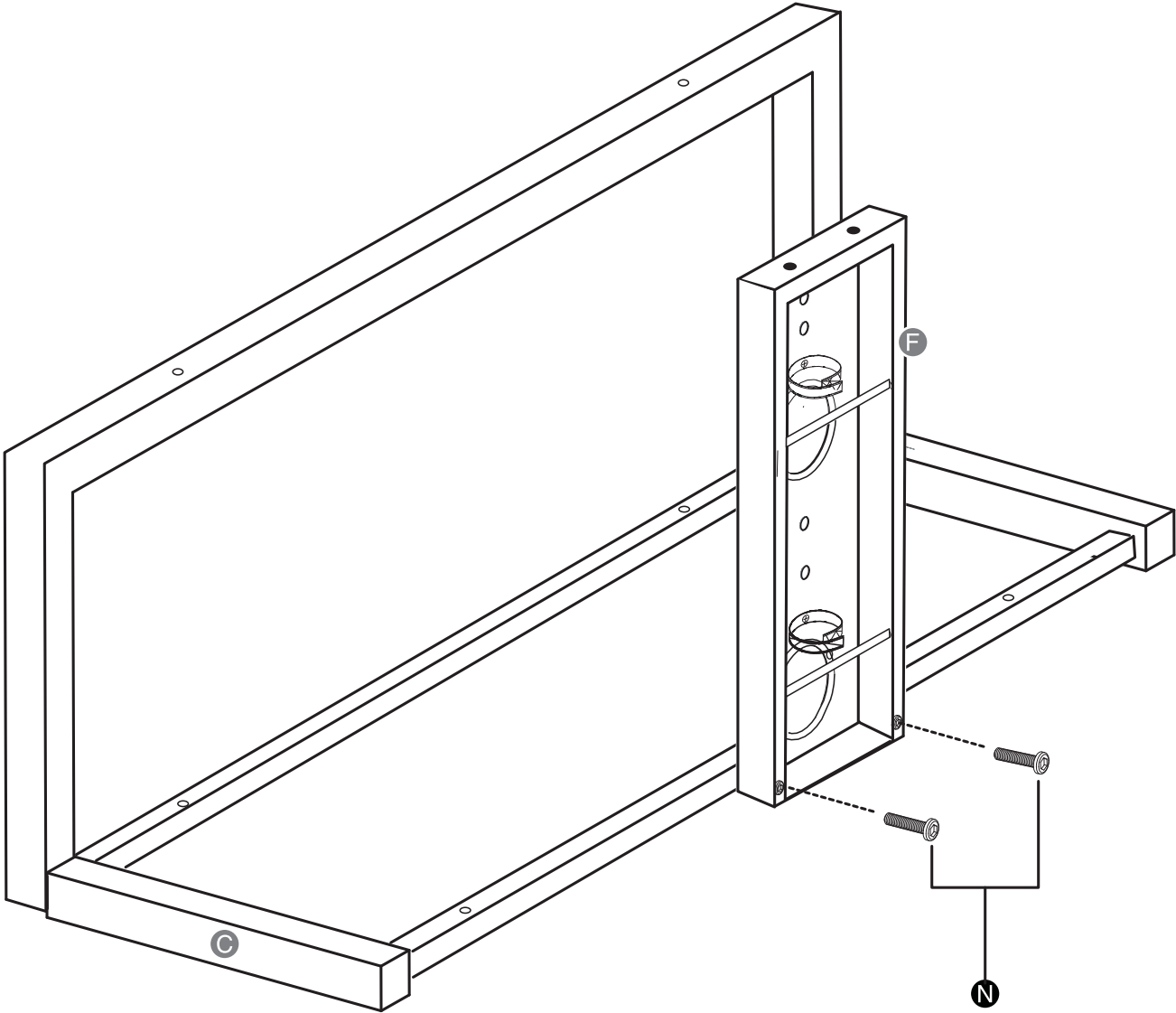

**You'll need:**



**N (2)**      **Q (1)**

**Step 3: Attaching the feet and suction cups**

- 1 Gently lay the stand on its side so the front of the stand is facing down, then screw six feet (**K**) into bottom of the stand (two feet into the left base, two feet into the right base, and two feet into the back base). Set the stand upright.
- 2 Insert a suction cup (**O**) into each end of the front and back bases.

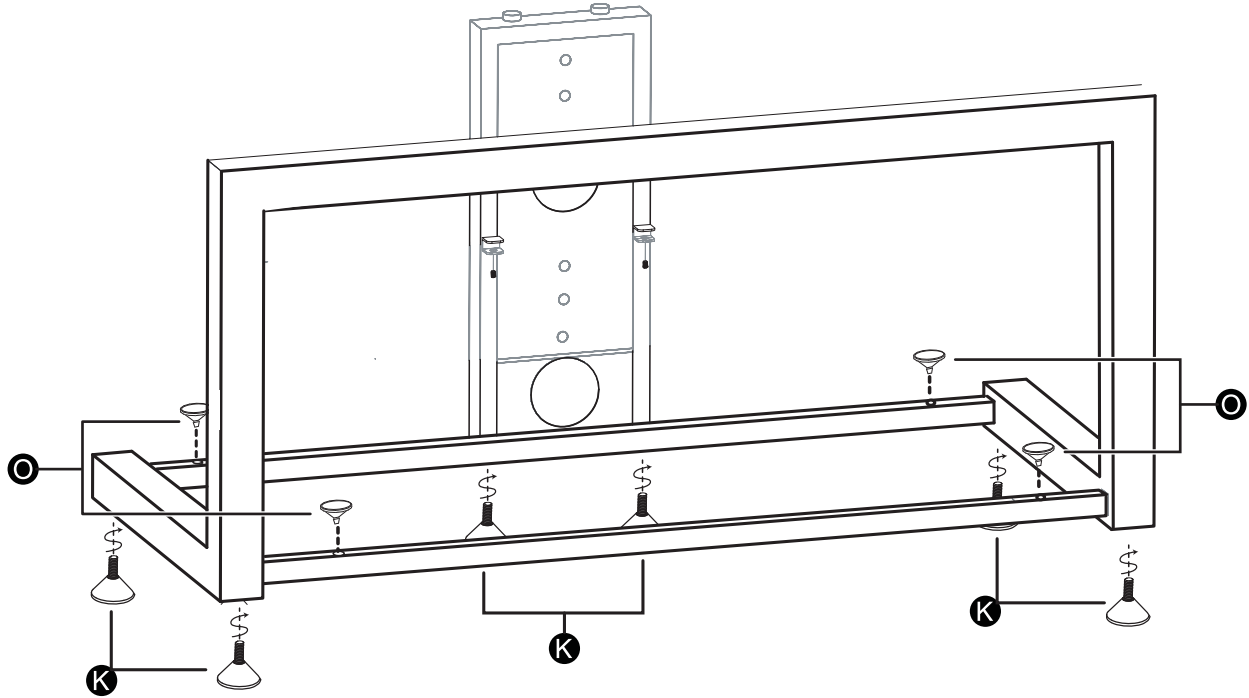
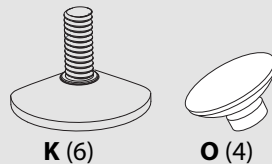
**You'll need:**

**Step 4: Attaching the top shelf**

- 1 Place the top shelf (G) on the stand frame so that the screw supports on the shelf align with the screw holes on the front support (A) and the rear support panel (F).
- 2 Screw the two pillar supports (H) through the screw holes on front support and into the screw supports on the top shelf (G).
- 3 Screw two medium screws (L) through the screw holes on the top of the rear support panel and into the screw supports on the top shelf (G).

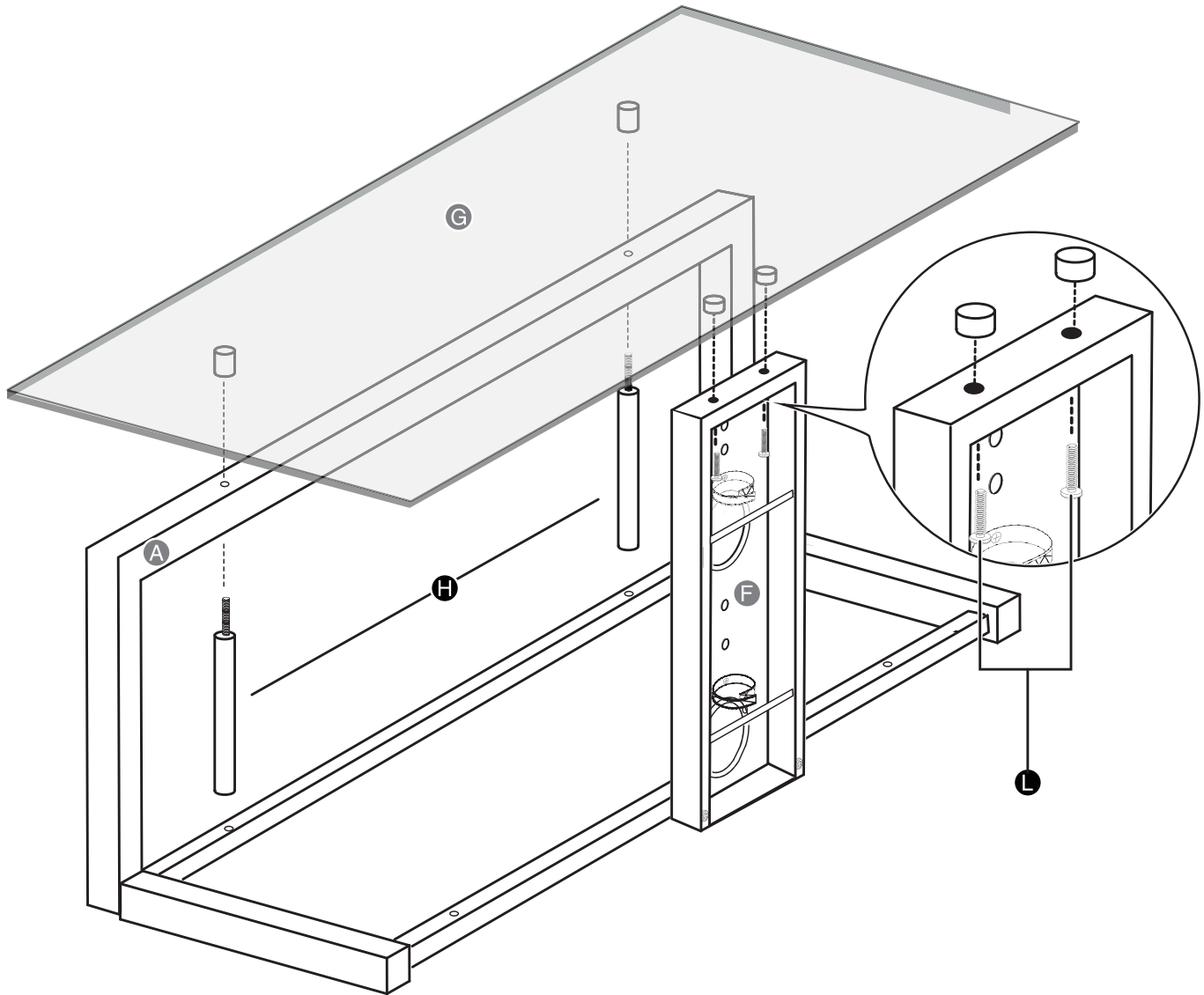
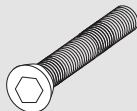
**You'll need:**

L (2)



Q (1)



**Step 5: Attaching the center shelf**

- 1 Slide the center shelf (I) into the shelf brackets on the rear support panel, then secure the center shelf (I) to the pillar supports (H) using two medium screws (L).
- 2 Secure the center shelf (I) to the shelf brackets by using two clamp screws (P).

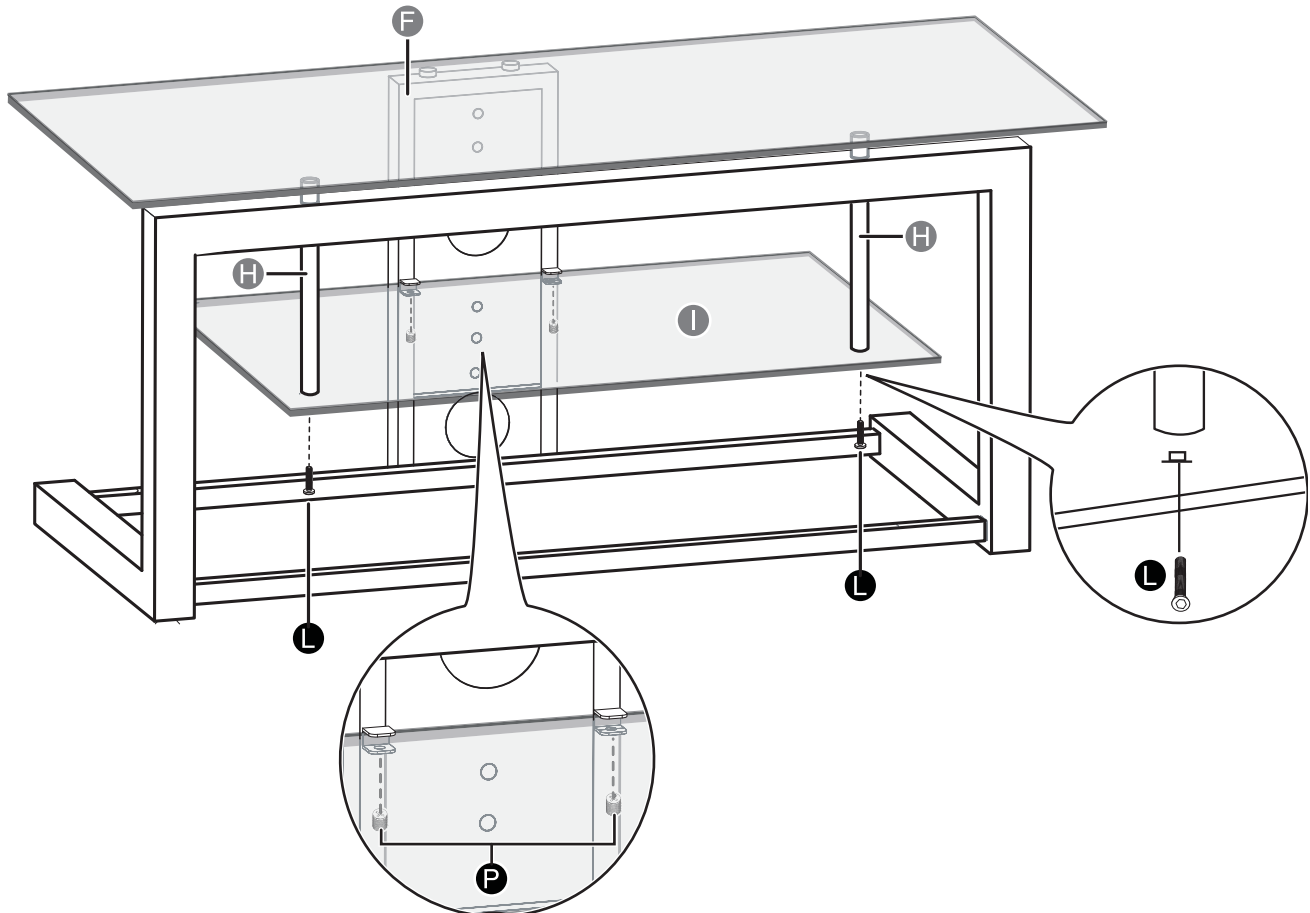

**Caution:** Do not tighten the two medium screws (L) too tightly.

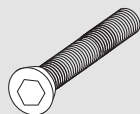
**You'll need:**

L (2)



P (2)



Q (1)

**Step 6: Attaching the bottom shelf**

- Place the bottom shelf (J) on top of the shelf pads with the slot facing the back of the stand. The rear support panel should fit into the slot in the bottom shelf (J).

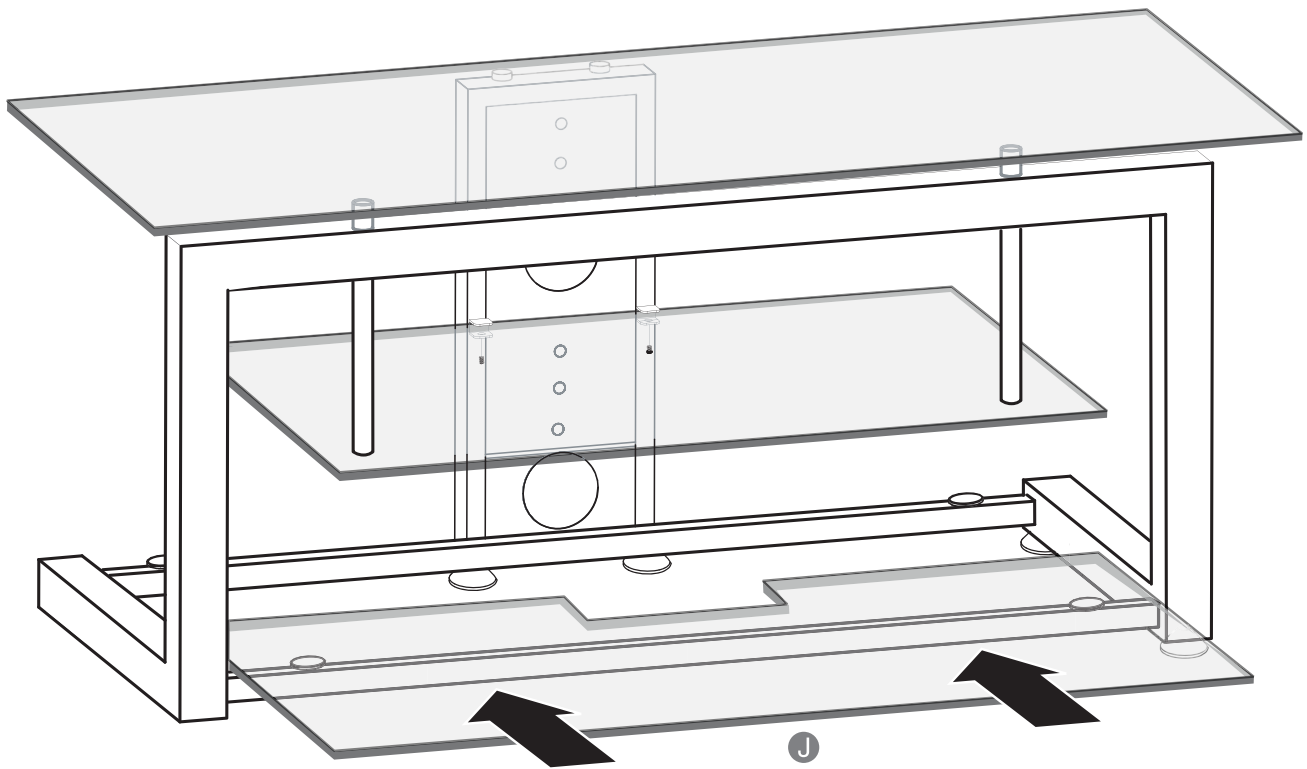

# CARE AND MAINTENANCE

## Glass

- Use a commercial liquid glass cleaner and a soft cloth.
- Do not use harsh powders or any other abrasive substances as they will scratch the glass.

**⚠ WARNING**

**Please use your stand correctly and safely. Improper use can cause safety hazards or damage to your furniture or household items. Carefully read the following chart.**

Look out for:	What can happen:	How to avoid the problem:
<ul style="list-style-type: none"> <li>• Children climbing on the stand.</li> <li>• A child may try to reach a toy or other object by climbing on the stand.</li> <li>• Children will play and be active near the TV.</li> </ul>	<ul style="list-style-type: none"> <li>• Risk of injury or death.</li> <li>• A child climbing on the stand can make it top-heavy and cause it to tip over.</li> <li>• A child playing with a TV can cause it to tip over.</li> </ul>	<ul style="list-style-type: none"> <li>• Never allow children to climb on or play with the stand.</li> <li>• Do not place toys or food on the top shelves. Children may try to climb to reach them out of curiosity.</li> </ul>
<ul style="list-style-type: none"> <li>• Improper use of the stand to support TVs.</li> <li>• The stand is designed for use with TVs will specify the maximum weight rating and recommended size of the TVs it will safely support.</li> </ul>	<ul style="list-style-type: none"> <li>• Risk of injury or death.</li> <li>• TVs can be very heavy. Note, older CRT TVs tend to be unbalanced and prone to tipping forward.</li> </ul>	<ul style="list-style-type: none"> <li>• A TV must only be set on furniture specifically designed to support a television.</li> <li>• Never use a TV that exceeds the weight ratings or size guidelines specified for the stand.</li> </ul>
<ul style="list-style-type: none"> <li>• Overloaded shelves</li> </ul>	<ul style="list-style-type: none"> <li>• Risk of injury.</li> <li>• Top-heavy furniture can tip over.</li> <li>• Overloaded shelves can break.</li> </ul>	<ul style="list-style-type: none"> <li>• Never exceed the weight limits. All shelves can support 100 lbs.</li> <li>• Work from the bottom to the top when loading shelves.</li> </ul>
<ul style="list-style-type: none"> <li>• Improperly moving the stand.</li> </ul>	<ul style="list-style-type: none"> <li>• The stand can tip over or break if improperly moved.</li> <li>• Risk of injury.</li> </ul>	<ul style="list-style-type: none"> <li>• Unload shelves from the top to the bottom before moving the stand.</li> <li>• Do not push the stand, especially on a carpeted floor. Have a friend help you lift the item and set it in place.</li> <li>• Do not lift the stand using the top shelf. Lift from the frame or leg assembly.</li> <li>• Remove the TV before moving the TV stand.</li> </ul>



# ONE-YEAR LIMITED WARRANTY - INSIGNIA

## Definitions:

The Distributor\* of Insignia branded products warrants to you, the original purchaser of this new Insignia-branded product ("Product"), that the Product shall be free of defects in the original manufacturer of the material or workmanship for a period of one (1) year from the date of your purchase of the Product ("Warranty Period").

For this warranty to apply, your Product must be purchased in the United States or Canada from a Best Buy branded or Future Shop branded retail store or online at [www.bestbuy.com](http://www.bestbuy.com), [www.bestbuy.ca](http://www.bestbuy.ca), or [www.futureshop.ca](http://www.futureshop.ca) and is packaged with this warranty statement.

## How long does the coverage last?

The Warranty Period lasts for 1 year (365 days) from the date you purchased the Product. Your purchase date is printed on the receipt you received with the Product.

## What does this warranty cover?

During the Warranty Period, if the original manufacture of the material or workmanship of the Product is determined to be defective by an authorized Insignia repair center or store personnel, Insignia will (at its sole option): (1) repair the Product with new or rebuilt parts; or (2) replace the Product at no charge with new or rebuilt comparable products or parts. Products and parts replaced under this warranty become the property of Insignia and are not returned to you. If service of Products or parts are required after the Warranty Period expires, you must pay all labor and parts charges. This warranty lasts as long as you own your Insignia Product during the Warranty Period. Warranty coverage terminates if you sell or otherwise transfer the Product.

## How to obtain warranty service?

If you purchased the Product at a Best Buy or Future Shop retail store location, please take your original receipt and the Product to any Best Buy or Future Shop store. Make sure that you place the Product in its original packaging or packaging that provides the same amount of protection as the original packaging. If you purchased the Product from a Best Buy or Future Shop online web site ([www.bestbuy.com](http://www.bestbuy.com), [www.bestbuy.ca](http://www.bestbuy.ca), or [www.futureshop.ca](http://www.futureshop.ca)), mail your original receipt and the Product to the address listed on the web site. Make sure that you put the Product in its original packaging or packaging that provides the same amount of protection as the original packaging.

To obtain warranty service, in the United States call 1-888-BESTBUY, Canada call 1-866-BESTBUY for Future Shop call 1-800-663-2275. Call agents may diagnose and correct the issue over the phone.

## Where is the warranty valid?

This warranty is valid only in the United States and Canada at Best Buy or Future Shop branded retail stores or websites to the original purchaser of the product in the county where the original purchase was made.

## What does the warranty not cover?

This warranty does not cover:

- Customer instruction/education
- Installation
- Set up adjustments
- Cosmetic damage
- Damage due to weather, lightning, and other acts of God, such as power surges
- Accidental damage
- Misuse
- Abuse
- Negligence
- Commercial purposes/use, including but not limited to use in a place of business or in communal areas of a multiple dwelling condominium or apartment complex, or otherwise used in a place of other than a private home.

- Modification of any part of the Product, including the antenna
- Display panel damaged by static (non-moving) images applied for lengthy periods (burn-in).
- Damage due to incorrect operation or maintenance
- Connection to an incorrect voltage or power supply
- Attempted repair by any person not authorized by Insignia to service the Product
- Products sold "as is" or "with all faults"
- Consumables, including but not limited to batteries (i.e. AA, AAA, C etc.)
- Products where the factory applied serial number has been altered or removed
- Loss or Theft of this product or any part of the product
- Display panels containing up to three (3) pixel failures (dots that are dark or incorrectly illuminated) grouped in an area smaller than one tenth (1/10) of the display size or up to five (5) pixel failures throughout the display. (Pixel based displays may contain a limited number of pixels that may not function normally.)
- Failures or Damage caused by any contact including but not limited to liquids, gels or pastes.

REPAIR REPLACEMENT AS PROVIDED UNDER THIS WARRANTY IS YOUR EXCLUSIVE REMEDY FOR BREACH OF WARRANTY. INSIGNIA SHALL NOT BE LIABLE FOR ANY INCIDENTAL OR CONSEQUENTIAL DAMAGES FOR THE BREACH OF ANY EXPRESS OR IMPLIED WARRANTY ON THIS PRODUCT, INCLUDING, BUT NOT LIMITED TO, LOST DATA, LOSS OF USE OF YOUR PRODUCT, LOST BUSINESS OR LOST PROFITS. INSIGNIA PRODUCTS MAKES NO OTHER EXPRESS WARRANTIES WITH RESPECT TO THE PRODUCT, ALL EXPRESS AND IMPLIED WARRANTIES FOR THE PRODUCT, INCLUDING, BUT NOT LIMITED TO, ANY IMPLIED WARRANTIES OF AND CONDITIONS OF MERCHANTABILITY AND FITNESS FOR A PARTICULAR PURPOSE, ARE LIMITED IN DURATION TO THE WARRANTY PERIOD SET FORTH ABOVE AND NO WARRANTIES, WHETHER EXPRESS OR IMPLIED, WILL APPLY AFTER THE WARRANTY PERIOD. SOME STATES, PROVINCES AND JURISDICTIONS DO NOT ALLOW LIMITATIONS ON HOW LONG AN IMPLIED WARRANTY LASTS, SO THE ABOVE LIMITATION MAY NOT APPLY TO YOU. THIS WARRANTY GIVES YOU SPECIFIC LEGAL RIGHTS, AND YOU MAY ALSO HAVE OTHER RIGHTS, WHICH VARY FROM STATE TO STATE OR PROVINCE TO PROVINCE.

Contact Insignia:

For customer service please call 1-877-467-4289  
[www.insigniaproducts.com](http://www.insigniaproducts.com)

INSIGNIA is a trademark of Best Buy and its affiliated companies.

Registered in some countries.

Distributed by Best Buy Purchasing, LLC

7601 Penn Ave South, Richfield, MN 55423 U.S.A.

©2014 Best Buy. All rights reserved.

Made in China

# INSIGNIA™

## **Certificate of Conformity**

1. This certificate applies to the Insignia Product identified by this instruction booklet.
2. This certificate applies to the compliance of this product with the CPSC Ban on Lead-Containing Paint (16 CFR 1303).
3. This product was manufactured for:  
Insignia

4. Date of Manufacture: \_\_\_\_\_

Lot number:

1-877-467-4289 (U.S. and Canada) or 01-800-926-3000 (Mexico)  
[www.insigniaproducts.com](http://www.insigniaproducts.com)

INSIGNIA is a trademark of Best Buy and its affiliated companies.  
Registered in some countries.  
Distributed by Best Buy Purchasing, LLC  
7601 Penn Ave South, Richfield, MN 55423 U.S.A.  
©2014 Best Buy. All rights reserved.  
Made in China

V1 ENGLISH  
14-0256